

ST

Dalla particolare forma arrotondata le doghe Atena serie ST consentono di creare un soffitto dall'originale effetto estetico.

With their rounded shape Atena ST staves give an original and unique appeal to the false ceiling.

SISTEMA ANTISISMICO LOCKING SYSTEM

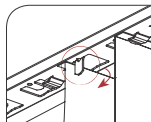

PIEGARE L'ALA DI SICUREZZA
BEND THE LOCKING WING

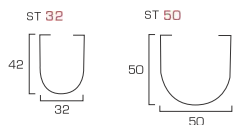
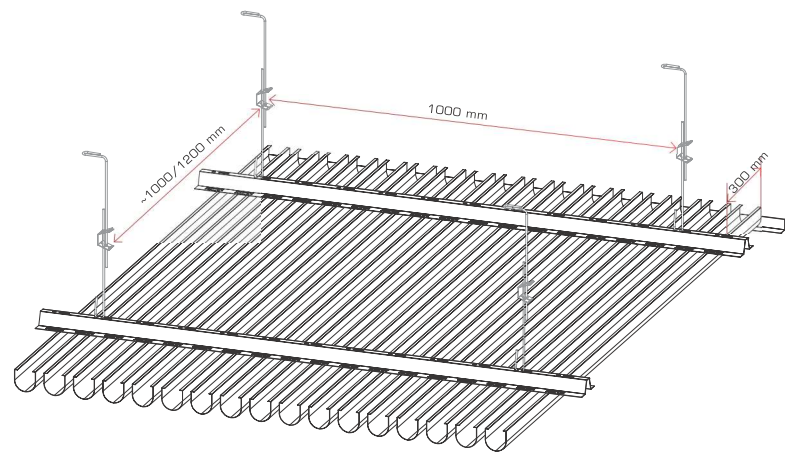

TRAVERSINA/CARRIER TS

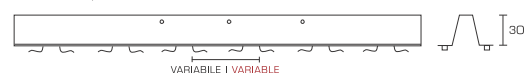

SEZIONE SECTION

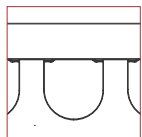

DETTAGLIO DETAIL

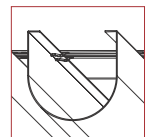

DETTAGLIO DETAIL

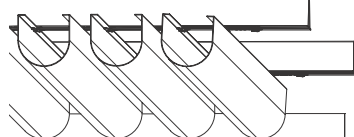

DESCRIZIONE / DESCRIPTION

TIPOLOGIA

Doghe in aggancio
Kit Antisismico su richiesta

PERIMETRALI E GIUNTI

Profilo perimetrale a "L" - "Doppia L" - "C"
Il sistema prevede specifici giunti per doghe e traversine

PENDINATURA

Standard con molla doppia

COLORI | FINITURE | FORATURE

Alluminio preverniciato bianco - silver
Acciaio preverniciato bianco - silver
Post verniciatura di qualsiasi colore Ral
Sublimazione di qualsiasi immagine ed effetto
Superficie liscia o forata

TYPE

Clip in staves
Antiseismic Kit on request

PERIMETER PROFILES AND JOINTS

Perimeter Profiles "L" - "Double L" - "C"
The system includes joints for staves and carriers

HANGERS

Standard with double spring

COLOURS | FINISHING | PERFORATION

White - silver prepainted aluminum
White - silver prepainted steel
Ral color post painting
Sublimation of any image and effect
Plain or perforated surface

DOGA STAVE	FUGA GAP	DIMENSIONI DIMENSIONS	SP. ALLUMINIO ALUMINUM THICK.	SP. ACCIAIO STEEL THICK.	TRAVERSINA CARRIER		INCIDENZE INCIDENCES ML/MQ	
					TIPOLOGIA TYPOLOGY	MATERIALE MATERIAL	DOGHE STAVES	TRAVERSINA T* CARRIER T*
ST 50	VARIABLE	L 50 - H 50	5/10 6/10	5/10	TS	ACC./STEEL 8/10	*	1
ST 32	VARIABLE	L 32 - H 42	5/10 6/10	5/10	TS	ACC./STEEL 8/10	*	1

* Incidenza variabile in funzione alla larghezza della fuga (Larghezza minima 10 mm) / * Variable incidence according to the gap width (minimum width 10 mm)

T* = Per specifici requisiti di progetto l'incidenza delle traversine e della pendinatura può variare. Si prega di verificare con l'U.T.I di Atena S.p.A.
T* = According project requirements incidence of carriers and suspensions can vary. Please check it with Atena S.p.A. technical department.



CLASSE 1



CLASSE C



NESSUNA
NONE



A1-A2s1d0